

TRUFAST® Adhesive Pump (TAP)

US patent 11,982,388



Recommended PPE

To gain a better understanding of correct PPE materials be sure to read the Safety Data Sheet (SDS) included with all adhesives before spraying.

Schematic

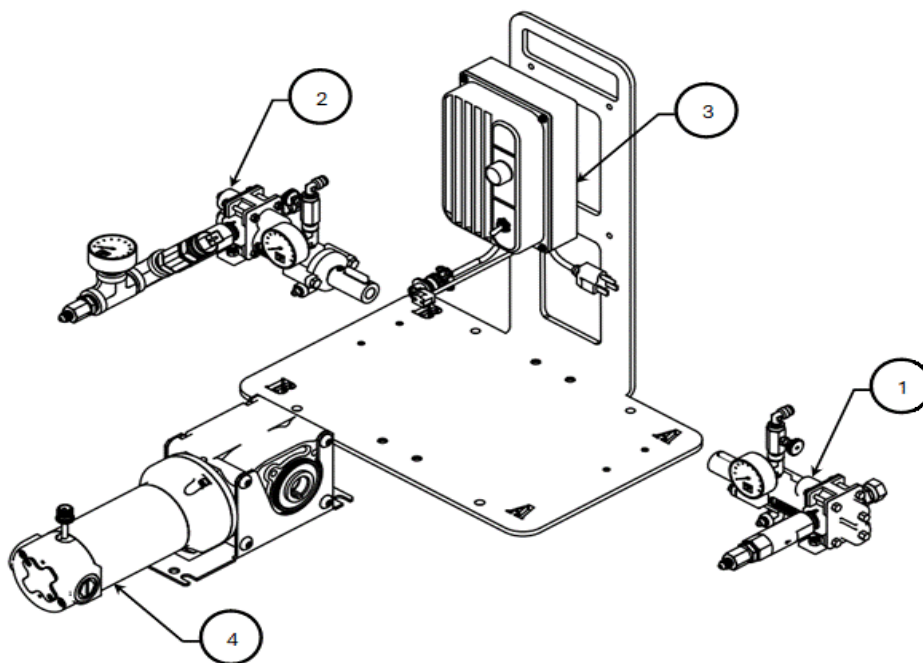

TRUFAST Adhesive Pump Parts List

Item	Part Description	Part Number	Quantity
	TRUFAST-TAP PUMP SYSTEM, COMPLETE-PACKAGED	TAP0001	
	TRUFAST-TAP PUMP SYSTEM COMPLETE KIT	TAP0001K	
1,2,3,& 4	TRUFAST-TAP COMPLETE PUMP ASSEMBLY	TAP0012	
	TRUFAST-TAP COMPLETE PUMP ASSEMBLY TOTAL KIT	TAP0012K	
1	TAP GEAR PUMP "A" SIDE, ASSEMBLY	TAP0022A	1
2	TAP GEAR PUMP "B" SIDE, ASSEMBLY	TAP0022B	1
3	TAP GEAR PUMP DC POWER SUPPLY, ASSEMBLY	TAP0023	1
4	TAP GEAR PUMP RIGHT ANGLE GEARMOTOR	TAP0022M	1



TRUFAST Adhesive Pump is distributed and serviced by

HAPCO

System Requirements/ Dimensions

Cart Dimensions					
	Length	Width	Height	Weight (Without Drums)	Weight (With Drums)
Cart (Handle Up)	59 ½"	33 ½"	30 ½"	189 lbs	464 lbs
Cart (Handle Down)	69 ¼"	33 ½"	30 ½"		

Power Requirements- Input Power		
120 Volts	1500 Watts	15 Amp Circuit

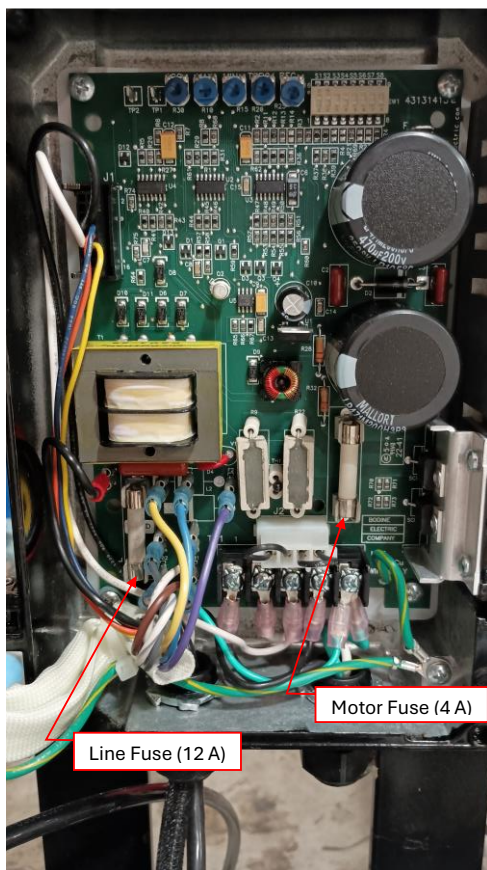

Lubricant Requirements for Pumps

Pumps will need the lubricant pressure to be 300 psi.
 (Upon setup, ensure 300 psi gauge pressure using provided grease, Super Lube).

Start-Up/ Shutdown

Assembly

1. Remove all boxes and verify contents:

- | | |
|-------------------------------|----------------------|
| a. chassis | g. static mixer |
| b. controller | h. desiccant filters |
| c. Mesamoll flush | i. drum straps |
| d. (8) bolts and nuts | j. dispense hose |
| e. gun | k. PTC manifolds |
| f. transfer hoses with valves | l. shower caps |
| | m. hose unions |

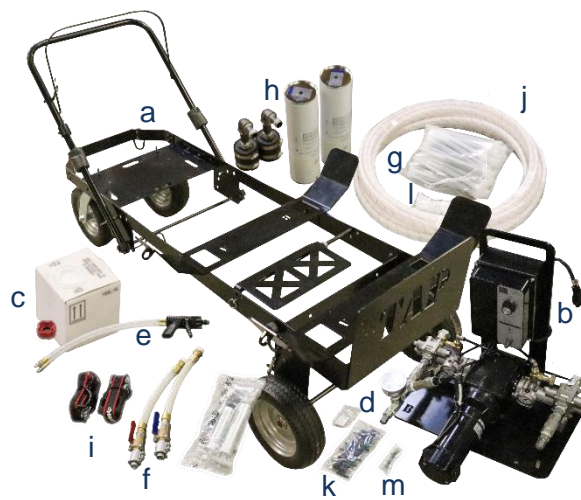

2. Remove the controller with bracket from its box and align the holes in the controller bracket with the studs on the frame.

3. Mount the controller bracket onto the cart using the wing nuts used to hold the controller to the skid.

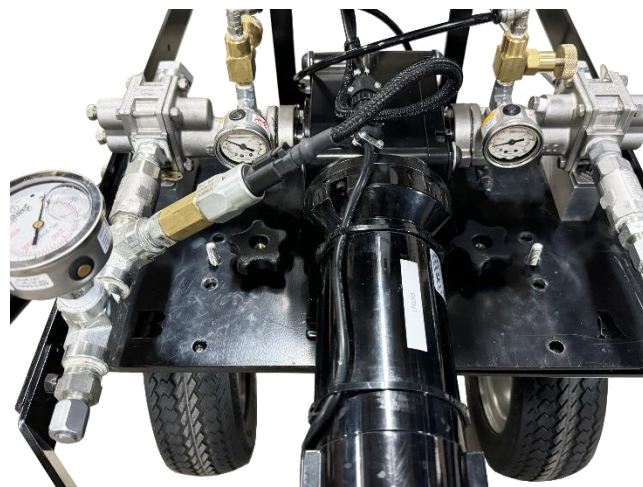

4. Remove dust caps and install transfer hoses using 2 adjustable wrenches.

- Red valve on A-side
- Blue valve on B-side

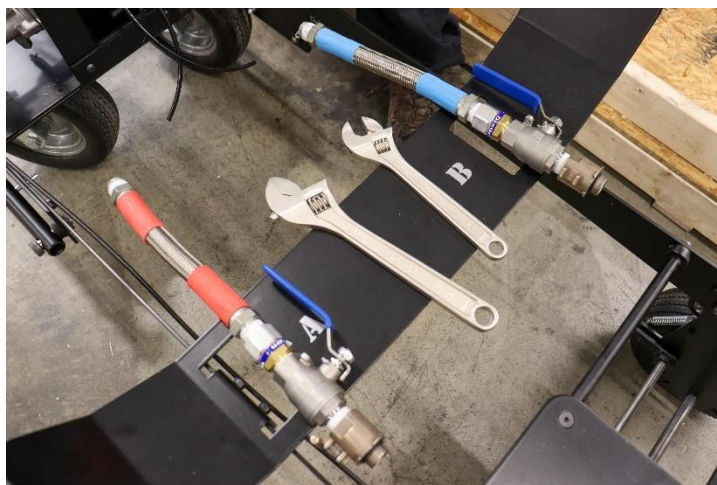

5. Finally, lift the cart handle to the desired position, and secure it in place with the hitch pins.



Assembly Complete

Start-up Guide

1. Stand the cart upright



2. Remove any protective films or covers from both ends of the desiccant cartridges, and then adjust clamps on rubber sleeves so that the desiccant filters will insert into the rubber sleeves on the desiccant assemblies.
3. Screw a desiccant assembly into each drum. Filter should be in a straight line from other plug.
4. Repeat the previous steps for the B-side.



5. Connect ratchet straps to the rings on the outside of the drum cradles and tighten the straps.



6. Open each drum by removing the inner (3/4") plug. Apply Super Lube to the seal of the Twist-Lok® (US patent 11,982,388). Raise the tee handle of the Twist-Lok® on the transfer and insert into the drum opening. Twist the Twist-Lok® by hand and using the ball valve lever, ensuring it's secure. Finally release the tee handle ensuring it seats behind one lobe of the plug.



7. Connect the 50' hose to the male #6 JIC fittings on the pump, matching the red side of the hose to the A-side pump and the blue side to the B-side pump to avoid cross-contamination of adhesives.
8. Use two adjustable wrenches to tighten the connections securely.

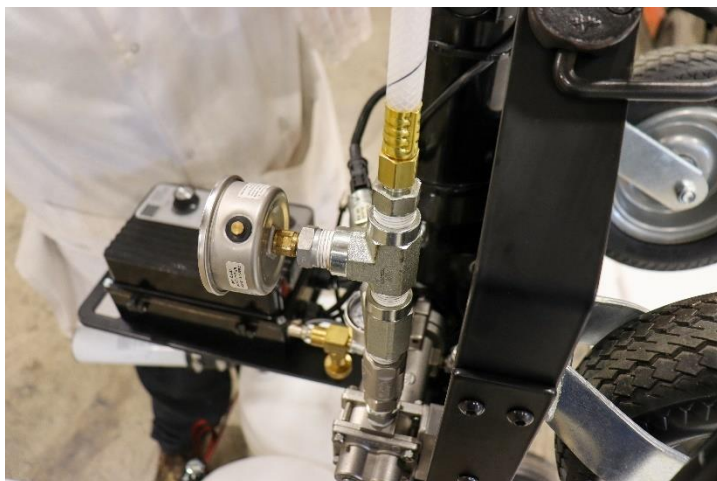

9. Connect the opposite end of the 50' hose with union to the gun, attaching it to the tubing at the back of the gun
 - a. Again, ensure a tight seal using two adjustable wrenches.

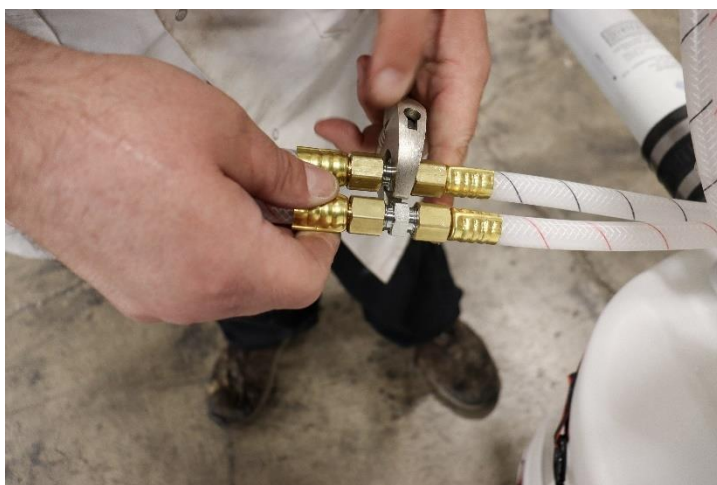

10. Apply Super Lube to the NOX valve (green cap)
 - a. **DO NOT THROW AWAY GREEN CAP. IT IS THERE TO PREVENT CROSS OVER OF THE ADHESIVES!**



11. Attach the static mixer to the gun



12. To prime the gun and prepare for spraying:

- a. Ensure cart has all 4 wheels on the ground
- b. Before plugging the pump into a 120V circuit, set the controller dial to **ZERO** and be sure **the toggle switch is "OFF"**.
- c. Plug pump into 120V circuit.
- d. Turn the toggle switch on and gradually increase the dial to 45%, *monitoring the pressure gauge to avoid exceeding 200 psi on the B-Side pressure gauge*
- e. Pull and hold the trigger on the gun handle throughout the filling process.



Shutdown

****Mesamoll is for daily flushing; NZD Iso-flush with Mesamoll after is for shutdown periods of 7+ days or for Contaminated hoses/ pumps****

1. Turn the dial on the controller to **ZERO** and **turn the switch to the off position.**
2. Close the ball valve on the A-side transfer line. This will prevent adhesive from entering your hose.
3. Stand the cart up vertically.

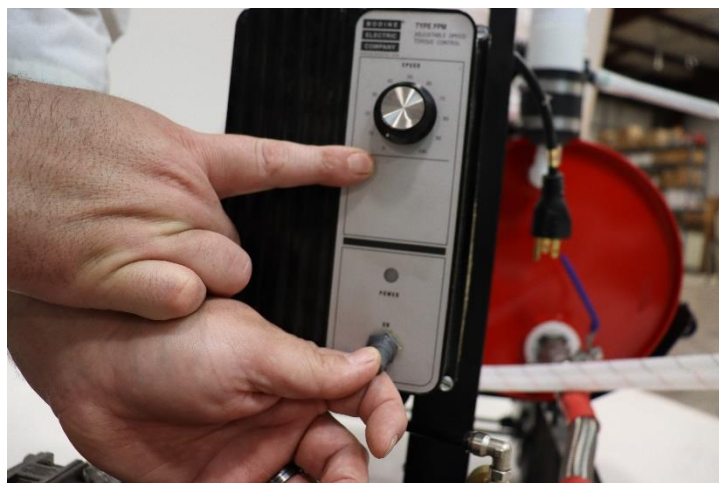

4. Disconnect the transfer line from the A-adhesive drum, use the small cap, 3/4" plug, that was in the drum to close the drum opening, and then loosen the straps holding the drums.
5. Remove the A-drum from the cart unless using 1 gallon flush container



6. Unscrew the cap off of the flush container of your choosing.
 - a. Mesamoll flush at the end of each day.
 - b. When storing for extended periods a thorough flush with Mesamoll is sufficient.

Note: If buildup of material is noticed in the transfer lines or pump, NZD ISO Flush can be used for a more aggressive cleaning process. **NZD ISO Flush is a harsh adhesive cleaning solution.** When flushing with NZD ISO Flush is complete, flush again with Mesamoll to prevent damage to the pump.



7. Screw the Twist Lock™ cap onto the flush container.



8. Connect the flush container to the transfer line by attaching the Twist Lock™ fitting and Twist Lock™ (US patent 11,982,388) cap using method described in step 6 of the start-up section.



9. Lay the cart back down on its wheels.
10. Hold the flush container if using 1 gallon flush container. If using 5 gallon container, remove A-Side drum and replace with flush container
11. Open the ball valve for flush to flow through



12. Turn the toggle switch to the ON POSITION

13. Move the dial to 45%



14. Once the system is powered on, press the gun trigger to allow flush to flow through the system and hose until it reaches the gun

- a. The color of adhesive in the A-side hose will become lighter as flush agents flow. From dark amber/brown to light amber/yellow for Mesamoll (about 90 seconds).



15. Turn the dial to ZERO and flip the toggle switch to the off position

16. Close the ball valves in the transfer line.

17. Stand cart up vertically.

18. Pump system is ready for storage.



Spraying

1. TRUFAST recommends an adhesive pull test over any reconditioned surface (recover) to ensure bond strength and structural integrity of the existing surface.
2. Before applying TRUFAST Roofing Adhesive, the surfaces to which the adhesive is being applied must be inspected to ensure that it is smooth, flat, clean, sound, dry, and free of any oil, sharp edges, loose and foreign materials, or irregular surfaces. Fibrous cement decks should be checked for their ability to retain the adhesive (some types may allow the adhesive to pass through).
3. Existing substrates that have residual asphalt must be cleaned and scraped smooth as best as possible. Any remaining asphalt that was not previously exposed (non-oxidized, glossy, shiny) must be primed with an approved primer (contact TRUFAST Technical Dept.).
4. When applying the TRUFAST Roofing Adhesive over existing materials/surfaces, any wet material must be removed, and the remaining moisture dried before the application. Do not use on substrates showing signs of deterioration or loss of structural integrity.
5. When spraying, use the dial on the front of the controller to adjust your spray volume. The pump shut-off pressure will stay the same.
 - a. Changing the controller dial setting will change the spray pattern.

Bead application (Insulation/cover board/thermal barriers):

6. Apply adhesive in 3/4"-1" width beads out of the mixer tip. Space beads 12", 6", or 4" apart according to roof designer specifications to ensure proper wind uplift performance.
7. The adhesive will then expand several inches in width and rise.
8. Once the adhesive has risen/foamed up, insulation boards may be placed onto the adhesive. Rise time may vary from 10-15 seconds on hot (100°F+) substrates to 5+ minutes on cold (32°F) substrates.
9. Tack/open/working time of the adhesive may vary from 1 minute on hot (100°F+) substrates to 10+ minutes on cold (32°F) substrates.
10. Apply ballast (buckets/pails/bags of weight) to insulation boards for 10-15 minutes after setting them onto the adhesive. Take care to ballast over joining board corners and edges as the adhesive will continue to rise and could cause uneven board edges without ballast.

Accessories

TRUFAST LPG Accessories	
Part Description	Part Number
TAP TWIST LOCK™ WITH T-HANDLE (W/KIT 2)	TAP0002
TAP TRANSFER HOSE ASSY. RED 14.25"	TAP0021HR
TAP TRANSFER HOSE ASSY. BLUE 14.25"	TAP0021HB
TAP TRANSFER HOSE ASSY SS RED 14.25"	TAP0021SSR
TAP TRANSFER HOSE ASSY SS BLUE 14.25"	TAP0021SSB
TAP TRANSFER HOSE ASSY BLUE 72"	TAP0021BH72
TAP TRANSFER HOSE ASSY RED 72"	TAP0021RH72
MESAMOLL, 1 GALLON W/TWIST LOCK™ CAP	TAP0003K
MESAMOLL, 5 GALLON W/TWIST LOCK™ CAP	TAP0004K
NZD ISO FLUSH 1/GAL	TAP0014K
NZD 5GAL	TAP0015K
TAP TWIST LOCK CAP FOR FLUSH JUG	TAP0020
TAP TWIST LOCK CAP PLUG	TAP0020P
TAP DRUM DESICCANT CARTRIDGE (W/KIT 2)	TAP0017
TAP DESICCANT DRUM ADAPTER 3/4" (W/KIT 2)	TAP0018
4 AMP FUSE (W/KIT 5)	TAP0005
TAP GUN ASSY, 3/8" WHIPS	TAP0008
TAP 3/8" TWINLINE HOSE ADAPTER	TAP0013
TAP TWINLINE HOSE 3/8" X 50FT	TAP0011
TAP MIX TIPS (W/KIT 50)	TAP0019
TAP SPATTER SHOWER CAP (W/KIT 50)	TAP0009
TAP PTC MIX MANIFOLD W/NOX VALVE (W/KIT 5)	TAP0010
TAP BUNG WRENCH	TAP0016
MINI GREASE GUN	TAP0006
TAP PUMP GREASE	TAP0007
BUNG WRENCH	TAP0016
LIQUID FILLED GAUGE, DISPENSE	TAP0022G
PRESSURE GAUGE, 0 - 600 PSI	TAP0022PG
PRESSURE SWITCH	TAP0022PS
SNUBBER	TAP0022S

Maintenance and Care

Flushing

The A-side pump must be routinely flushed to avoid crystallization of Isocyanate. After each use, residual A-side adhesive will remain in the pump and associated lines. If not properly flushed, this residual material can harden or crystalize over time, leading to clogs, inconsistent adhesive spray, or a seized A-side pump. Flushing of the B-side pump is not required.

Flushing the pump typically involves running Mesamoll through the pump and lines to remove any remaining adhesive. This process helps keep the pump clean and free of residue, ensuring reliable performance and prolonging the life of the equipment.

Use Mesamoll to flush your system daily. If you plan to shut your system down for an extended amount of time, use Mesamoll. When storing for extended periods a thorough flush with Mesamoll is sufficient. **Note:** If buildup of material is noticed in the transfer lines or pump, NZD ISO Flush can be used for a more aggressive cleaning process. **NZD ISO Flush is a harsh adhesive cleaning solution.** When flushing with NZD ISO Flush is complete, flush again with Mesamoll to prevent damage to the pump. and then with Mesamoll. Flushing through the pump and hose should use about one half gallon for the A-side.

Filling the pumps with lubricant

- Check the gauges daily to be sure there is correct lube pressure.
- Purge lube weekly in **BOTH A & B PUMPS** - flush until lube comes out clean and white
- When changing lube - put down cardboard or protective covering to avoid spilling lube onto roof
- Connect grease gun to zerk fitting. You must maintain a lubricant pressure of 300 psi. This is important for proper operation of the mechanical seals in the gear pumps. This pressure is displayed on the 1.5" gauges on each gear pump. A pressure of 300 psi is required.
- Operating line pressure is displayed on the larger, 2" gauge found on the 'B' side pump

Caring for your adhesive

- Keep containers closed tightly during transport and storage.
- Protect containers from puncture during transport.
- Protect from moisture, direct sunlight, and freezing temperatures (32°F/0°C).
- The ideal storage temperature is 55-90°F to achieve a maximum product shelf life of 12 months.



TRUFAST Adhesive Pump is distributed and serviced by

HAPCO

- Storage conditions outside of the above recommendations will shorten product shelf life.

Disposal and Cleanup

- Uncured adhesive can be cleaned with solvents such as mineral spirits, xylene, etc. Cured adhesive can be scrapped from surfaces with a metal scrapper.
- Individual A-side or B-side adhesive components in their liquid state should be treated as hazardous waste and disposed of in a licensed facility according to federal, state, and local regulations.
- Empty containers, 15-gallon, and 55-gallon drums can be disposed of in most landfills as non-hazardous waste if there is less than 1 inch of residue in the drum. However, consult federal, state, and local regulations for your specific location concerning the handling and disposal of hazardous and non-hazardous waste.

Troubleshooting Guide

Problem	Cause	Solution
Gear motor doesn't turn	<p>Unplugged connection (Three-Pin Circular Connector)</p> <p>Crystallized adhesive in A-side pump</p>	<p>Plug in the three-pin circle connector</p> <p>If adhesive has crystallized in the A-side gear pump, remove all fittings from the two sides. Once the fittings have been removed, use a pick to knock crystallized adhesive off of the gears and the shaft. In addition to this, the shaft can be spun backwards from its' normal direction of spin, to release crystallized adhesive as well. Using AEROSOL BRAKE CLEANER can help loosen the crystallized adhesive. Contact your distributor for a replacement pump.</p>
Unit is surging	Pressure setting is too high	Reduce the pressure of the system using the dial on the controller. If the surge does not reduce, check the pressure switch and/ or snubber.
Pump does not shut off when spraying stops	<p>Snubber is blocked</p> <p>Pressure switch is broken</p>	<p>Remove the snubber from the B-side pump and spray brake cleaner through it. DO NOT USE WATER! If the brake cleaner does not exit the other side, the snubber is blocked and needs to be cleaned out.</p> <p>Check the cable to the controller</p> <p>Check the cable to the pressure switch (Deutsch Connector)</p>

Problem	Cause	Solution
<p>Adhesive does not come out of gun</p> <p>Heat the adhesive to at least 50 degrees fahrenheit</p>	<p>Empty Drum</p> <p>Desiccant cartridge still has a seal on it</p> <p>Crystalized adhesive in the pump, hose, gun, or nozzle</p>	<p>Exchange the empty drum with a full drum</p> <p>Remove the seals off both ends of the desiccant cartridge</p> <p>Flush the system with NZD Iso Flush and check for damage to the pump, hose, gun, or nozzle</p>
<p>Controller does not turn on</p>	<p>Ensure the system is plugged into a 120V circuit</p> <p>Blown Line Fuse</p>	<p>First, ensure the extension cord is functional and delivers 110 - 120 Volts AC. Next, while the system is unplugged use a ¼" nut driver to remove the bolts at each of the four corners on the controller (The screws are captive and will not fall out). Open the door and look at the screw terminals located at the bottom of the housing. Of the 5 screw terminals, the two on the left are power IN. CHECK FOR LOOSE CONNECTIONS! If connections are secure, replace fuse FA. If this does not fix the controller, contact your distributor for a replacement controller.</p> <p>If Line Fuse is blown, replace the fuse with another 12 amp fuse and check for proper function of the controller. USE ONLY 12 AMP FAST ACTING FUSE!</p>

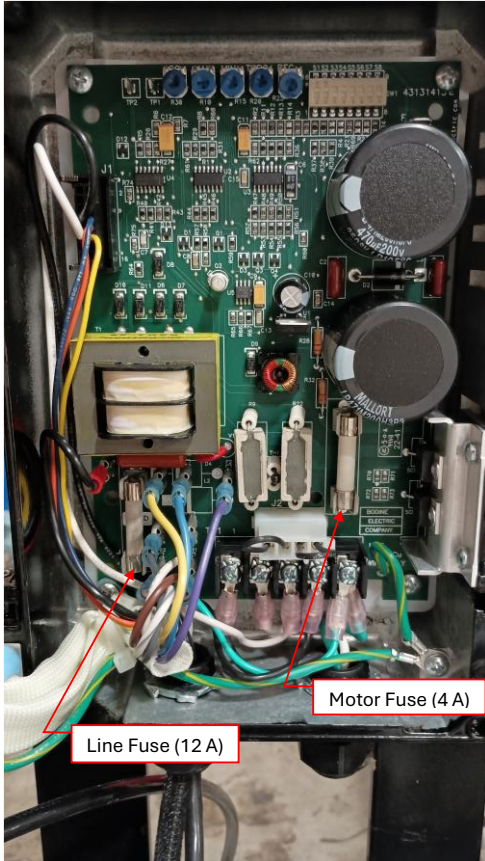
Problem	Cause	Solution
<p>Controller power light is on, but motor will not turn</p>	<p>Blown Motor Fuse</p>	 <p>If Motor Fuse is blown, replace the fuse with another 4 amp fuse and check for proper function of the controller. USE ONLY 4 AMP TIME DELAY FUSE!</p>
<p>Lubricant pressure drops</p>	<p>Needle valve is not closed</p> <p>Pump seals have started leaking</p>	<p>Ensure the needle valves are closed by twisting the knob to the right. (When facing the knob)</p> <p>Replace the pump</p>
<p>Brake system will not engage</p>	<p>Brake spring has been stretched out over time</p>	<p>Replace the spring</p>

	<p>Brake handle has not been released</p> <p>Ensure the slots on the brake wheels have been aligned</p> <p>Broken brake pin</p>	<p>Release the brake handle</p> <p>Align the cart to drop the brake pins into place</p> <p>Replace cart</p>
Decrease in flow rate	<p>Blocked hose, transfer or dispense</p> <p>Blocked Tip or Manifold on Gun</p> <p>Temperature of adhesive is too low</p>	<p>Replace Hose</p> <p>Replace Tip or Manifold</p> <p>Warm up adhesive using a powered blanket or (other method of heating adhesive)</p>
Crunchy adhesive	<p>Not enough B-side flowing through pump</p>	<p>Check for contaminants in the B-side pump</p> <p>Make sure seals are removed from B Desiccant cartridge</p> <p>Check nozzles for blockages.</p>

Problem	Cause	Solution
Slow Rise Foam Brittle, Crunchy Foam Yellow in Color	Lack of B-side adhesive	Check for clogging or contamination in the B-side Pump Seals still on B-side Desiccant cartridge, remove seals
Quick Reacting Foam Blue-Grey Color Soft, Flexible Foam	Lack of A-side adhesive	Check for clogging or contamination in the A-side Pump Seals still on A-side Desiccant cartridge, remove seals
Adhesive too Viscous	Adhesive temperature is too cold	Heat adhesive to at least 70°F
Adhesive does not stick to the substrate	Substrate temperature is too cold	Wait for the substrate to warm up or heat it to above 32°F
Cart will not move	Brake Handle hasn't been engaged Brake spring has been stretched out/ broken Brake cable has broken	The brake handle must be pressed down to release the brake system. Inspect the spring on the brake assembly closely to determine if the spring has been stretched too far, or if it has been broken via wear and tear. Determine if a replacement is necessary. Inspect the brake cable for cuts to determine whether a replacement is required.

For TAP Adhesive Pump questions, sales, and supplies contact:

Hapco, Inc.
1-800-345-9353
www.hapcoinc.com

To order more TRUFAST Roofing Adhesive, contact:

TRUFAST
1-800-443-9602
www.trufast.com