HERZ

Hochdruck-
gebläse
HD

D A

Herz Hochdruckgebläse - Betriebsanleitung

GB IRL

Herz high-pressure blowers – Operating instructions

F B L

Ventilateurs haute pression Herz – Notice d'utilisation

I

Ventilatori ad alta pressione Herz – Istruzioni per l'uso

HU

Herz Oldalcsatornás légellátó - Használati útmutató

HD 240

HERZ

Herz GmbH

Biberweg 1, D-56566 Neuwied
Telefon +49 (0)26 22 / 8 10 86
Telefax +49 (0)26 22 / 8 10 80
Internet <http://www.herz-gmbh.com>
E-mail: info@herz-gmbh.com

INDEX

1.	GENERAL INSTRUCTIONS	10
1.1	CONDITIONS OF USE	10
1.2	STORAGE AND SHIPPING	10
1.3	INSTALLATION	10
1.3.1	FJET BLOWER - EXHAUSTER	10
1.3.2	ELECTRIC MOTOR	11
1.3.2.1	CURRENT MEASUREMENT	11
1.4	COMMISSIONING	11
1.5	OPERATING ADJUSTMENTS	11
1.6	MAINTENANCE	11
2.	INSTALLATION SKETCHES	12
2.1	PRESSURE SERVICE	12
2.2	PARALLEL PRESSURE SERVICE	12
2.3	SERIES PRESSURE SERVICE	12
2.4	VACUUM SERVICE	12
2.5	PARALLEL VACUUM SERVICE	12
2.6	GAS TRANSFER	12
2.7	LIST ACCESSORIES	12
3.	INTERNAL CLEANING INSTRUCTIONS	13
3.1	CLEANING INSTRUCTIONS	13
3.2	REPLACEMENT SOUND-ABSORBING PANELS	13
4.	SILENCER HOUSING MOUNTING INSTRUCTIONS	14
4.1	USING THE 90° MANIFOLD KIT TYPE CK	14

1. GENERAL INSTRUCTIONS

CAUTION

The 'FJET' blowers - exhausters have been designed and manufactured for use in an industrial environment, operated by qualified personnel and as a unit to be incorporated in a machine, which conforms to the CE Machinery Directive.



The 'FJET' blowers - exhausters, like all machinery and equipment with live and moving parts, can be a source of serious hazards unless properly used and protected.

The user is committed to ensure that:

All handling, assembly, installation, connection, maintenance and repair operations are undertaken by qualified personnel. Such people who by their background, training and experience as well as through their knowledge of statutory regulations, legislation, safety measures and operating conditions are able to carry out any necessary steps avoiding all possible risks to health and damage.



Such personnel should have received all the instructions and information, including any local legislation, and will follow them during the performance of any operation.

It shall be forbidden for unqualified personnel to carry out any operation, even indirectly, on the machines and equipment.

During the installation, all the prescribed working conditions, including any possible local requirements, shall be observed. Additionally it is forbidden to put the unit in service before the machines of which they are a part are declared to conform to the CE Machinery Directive.

The user must be aware that in operation:

- • the surface temperatures can reach 160°C;
- • the unit cannot contain high internal pressures, no greater than Ps referred to in SN 1867;
- • there is small loss of the fluid handled;
- • the level of noise may be unacceptable in certain applications.

1.1 CONDITIONS OF USE

The 'FJET' blowers - exhausters are designed for the continuous movement of air or non-explosive, non-hazardous and nonflammable gases and for service in non-explosive environments.

Solid particles, however small, including dirt can cause serious damage; therefore it is essential that such substances should be removed from the gas by suitable filters upstream of the inlet. (Units which do not have an adequate filter ARE NOT COVERED BY THE GUARANTEE).

The maximum driving pressure must never be exceeded (Δp_{max} of SN 1867).

UNDER NO CIRCUMSTANCES OPERATE THE UNIT WITH THE GAS INLET OR OUTLET CLOSED. IN PARTICULAR THIS APPLIES TO THE UNITS WITH THE CAPACITY FOR HIGHER DRIVING PRESSURES.

Protect the units with an appropriate safety valve.

The performance characteristics are liable to variations due to the following factors:

- • Differences of the suction or discharge pressures from the reference conditions (1013 mbar);
- • Operation in a system with both a low suction pressure and a high back pressure;
- • Operation with a gas at a different temperature or of a different specific gravity from the reference data (1.23 kg/m³; 15 °C);
- • Variations in the rotational velocity of the fan with respect to the reference value.

Both the gas inlet temperature and the ambient temperature must be in the range of -15°C to +40°C.

At the same time, ensure that the unit has good ambient ventilation, especially when subjected to severe operating conditions. A unit subjected to frequent starting or to high ambient temperatures may be prone to overheating and in such cases further information should be requested. Similarly, where flammable gases may be present, information must be requested for alternative models certified for the Ex. environment.

1.2 STORAGE AND SHIPPING

Store the unit in a dry place, preferably in original packaging.

Do not remove the protection plugs from the ports. Avoid stacking anything on top of the packaging.

To move the packed boxes, use the largest pallet or support base possible to obtain the maximum stability.

On all occasions handle the units with care and avoid sudden impacts. Lifting eyes are provided to unpack units weighting more than 25 kg. (The weight of the unit is M in SN 1867).

1.3.1.1 INSTALLATION

1.3.2 'FJET' BLOWER – EXHAUSTER

It is important that the unit is installed in a well-ventilated environment where the temperature does not exceed 40°C.

If outside, protect the unit from direct sunlight and avoid the possibility of water collecting in the external crevices especially when installed with the axis vertical.

IMPORTANT!

Ingress of foreign matter, however small, will cause serious damage.

Such matter includes dust, sand, masonry debris, impurities in the tubes, cutting burrs or filings, welding or soldering slag and splatter, metal burrs and any residues from sealing and making the tube connections.

The unit can be mounted with the axis in any position. As supplied, the unit is balanced and will not transmit vibrations, however it is recommended that it be mounted on vibration damping supports. To connect the accessories, remove the flanges from the unit and then seal and tighten.

Do not over tighten remembering that the operating pressures are low.

Tube connections must be made with flexible couplings. Avoid using rigid couplings, which will induce stress and cause harmful vibrations.

Remember to protect the inlet with suitable filters.

If it is necessary to regulate the flow, install a bypass valve (refer to section 1.5).

Only remove the plugs on the ports when making the final connections.

Select the tube size and the couplings to minimize the pressure drop, in particular:

- Do not use tubing of a smaller diameter than the ports of the unit; When installing units in parallel, size the manifold and main conduit accordingly;
- Utilise large radius bends and avoid using elbows;
- Avoid using valves which have a reduced orifice relative to the general system; Use swing check valves (utilising lightweight discs) which have the lowest pressure drop, rather than spring loaded check valves;
- For oxygenation select low loss diffusers (lowest pressure drop) and note that the pressure drop across plugs and porous membranes will increase over time due to progressive clogging.

A safety relief valve should be installed to avoid overloading the unit as a result of pressure differential variations.

Make the electrical connections to the motor and check the direction of rotation before connecting the conduit.

The 'FJET' blowers - exhausters are already supplied as standard with silencers in the suction and exhaust ports (the noise levels Lp and Lw, with piped inlet and outlet flow, are detailed in SN 1867).

For operation into free air (either suction or discharge) the free flow noise can be muffled with additional silencers.

In every situation avoid installing the unit on a structure, which can transmit or amplify any noise (tanks, sheet metal etc.).

Installation sketches - please refer to next page.

Further information should be requested regarding additional noise reduction by installing the unit in soundproof enclosures.

1.3.2 ELECTRIC MOTOR

WARNING

BEFORE UNDERTAKING ANY OPERATION ENSURE THAT THE UNIT IS DISCONNECTED FROM THE ELECTRICITY SUPPLY.

The electric motor has been selected for service in an ambient temperature between -15°C and +40°C at an altitude no higher than 1000 m. Ensure that the information on the nameplate is consistent with the supply voltage and frequency. Variations in the supply voltage up to ± 10% are acceptable. Outside the normal operating conditions the motor cannot deliver full power and problems can arise with starting, especially for single-phase motors.

Make the electrical connections referring to the wiring diagram in the terminal box, connecting an earth cable of adequate capacity to the earth terminal.

The fuses are designed only for short circuit protection and not to safeguard the motor. Therefore overload cut-outs (temperature or current) are essential to guard against the risk of overloads on the motor --- for example failure of one line in a three phase supply, an excessively high start up frequency, unacceptable variations in the supply voltage, stalled rotor, etc.. Set the overload cutouts at the nominal current specified on the nameplate.

The fuses should be rated for the peak currents or use "slow blow" fuses especially in applications of direct starting.

THE ENTIRE GUARANTEE SHALL CEASE TO APPLY WHEN INADEQUATE PROTECTION IS PROVIDED.

1.3.2.1 CURRENT MEASUREMENT

The current drawn refers to normal operating conditions. Departures from the nominal operating conditions can result in variations of 10%.

There can be small differences in the measured value of each phase. These are tolerable up to a maximum deviation of 9% (ref. IEC 34-1).

1.4 COMMISSIONING

To commission the unit:

- Set the operating pressure or vacuum using a suitable gauge.
- Check the relieving pressure of the safety valve.
- Measure the current drawn by the motor and verify that it is within the limit stated on the name plate (refer to Para. 1.3.2.1).
- Adjust the overload cutouts accordingly.
- After one hour's operation, repeat the current measurements and verify that they are still within the stated limits.

1.5 OPERATING ADJUSTMENTS

The 'FJET' blowers - exhausters will automatically generate the driving pressure required at the point of use.

Since the power absorbed and the operating temperature is primarily a function of the driving pressure, it is possible that these can exceed the permitted operating conditions for the unit. Frequently the pressure losses of the tubing are overlooked as the major factor determining the driving pressure.

The driving pressure can be reduced by eliminating all possible obstructions and restrictions in the flow path. If it is still too high, the flow can be reduced by installing a bypass valve.

Never choke the flow by throttling the suction or the discharge.

1.6 MAINTENANCE

After every 10-15 days of use clean the cartridge filter. Replace the cartridge frequently in dusty environments.

A dirty filter will create a strong suction resistance and consequently a higher driving pressure, a higher operating temperature and an increase in the absorbed power.

Check that the driving pressure does not change over time.

It is important that a unit in service is subjected to periodic inspections by qualified personnel to insure against failures, which, directly or indirectly, could cause damage.

Departures from the normal operating conditions (e.g. a rise in the absorbed power, unusual operating noises, vibrations, etc.) are a sign of abnormal operation, which can lead to failure.

In the event of difficulties please contact CBI or the relevant sales agent.

Please note that repairs undertaken by a third party will invalidate the guarantee.

Periodically remove any surface deposits which otherwise can cause the operating temperature to rise.

Commitments, agreements or legal relationships are governed by the corresponding sales contract. The above items are in no way limited by the contents of this manual. The quality of the materials and of the workmanship is guaranteed as set out by the standard conditions of sales. The guarantee is not valid for the following: damage incurred during transport; inadequate storage; faulty installation; incorrect use; exceeding performance limits; electrical or mechanical miss-use.

Store the packaging for possible future use.

2. INSTALLATION SKETCHES

2.1 PRESSURE SERVICE

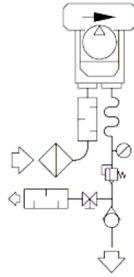

2.4 VACUUM SERVICE

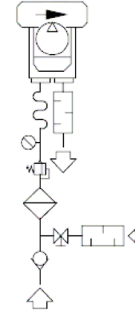

2.2 PARALLEL PRESSURE SERVICE

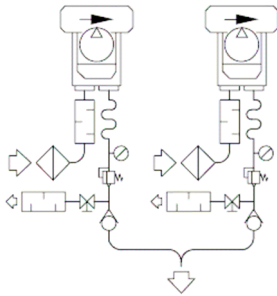

2.5 PARALLEL VACUUM SERVICE

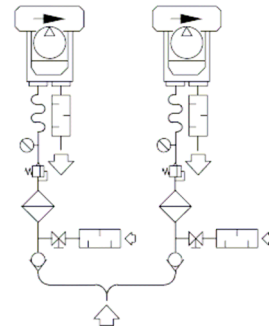

2.3 SERIES PRESSURE SERVICE

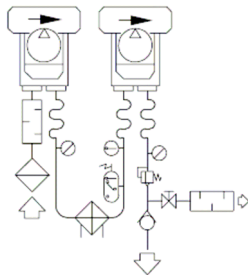

2.6 GAS TRANSFER

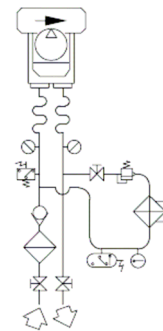

2.7 LIST ACCESSORIES

Item		Denomination	Item		Denomination
1		Filter – Inline filter	7		Check valve
(2)		Silencer	8		Valve
3		Flexible coupling	(9)		Cooler
4		Pressure – Vacuum gauge	(10)		Thermometer
5		Pressure – Vacuum switch	(11)		Temperature switch
6		Relief valve	(x) IF NECESSARY		

3. INTERNAL CLEANING INSTRUCTIONS

CAUTION!

Internal deposit build up can cause:

- performance variations;
- alteration in clearances resulting in seizing;
- out of balance rotor.

3.1 CLEANING INSTRUCTIONS

In case it is necessary to clean the inside of the blower, proceed as follows:

1. Remove #183 foot through the extraction of #920 4 x screws.
2. Remove in order #915 and #902 screws placed on #162 cover.
3. Remove #162 cover by using the two holes between #161 body and #162 cover.
4. Remove the #900 screw and #365 washer.
5. Remove the #360 bearing cover and extract the #321 bearing using a bearing puller.
6. Remove the #230 impeller if necessary using a puller.
7. Clean and reassemble in reverse order.

If needed, reconstruct #423 seal using Loctite 598 or similar, after cleaning the sealing surfaces of any existing sealant.

3.2 REPLACEMENT SOUND-ABSORBING PANELS

If needed, replace the foam sound-absorbing panels, proceed as follows:

1. Remove #906 bolts.
2. Take away the #700 silencers from the unit, being careful not to lose the #424 gaskets.
3. Extract the #720 panels from the silencer housings.
4. Clean up the #710 retaining screen.
5. Replace and reassemble proceeding in reverse order, remembering to include the #424 gaskets

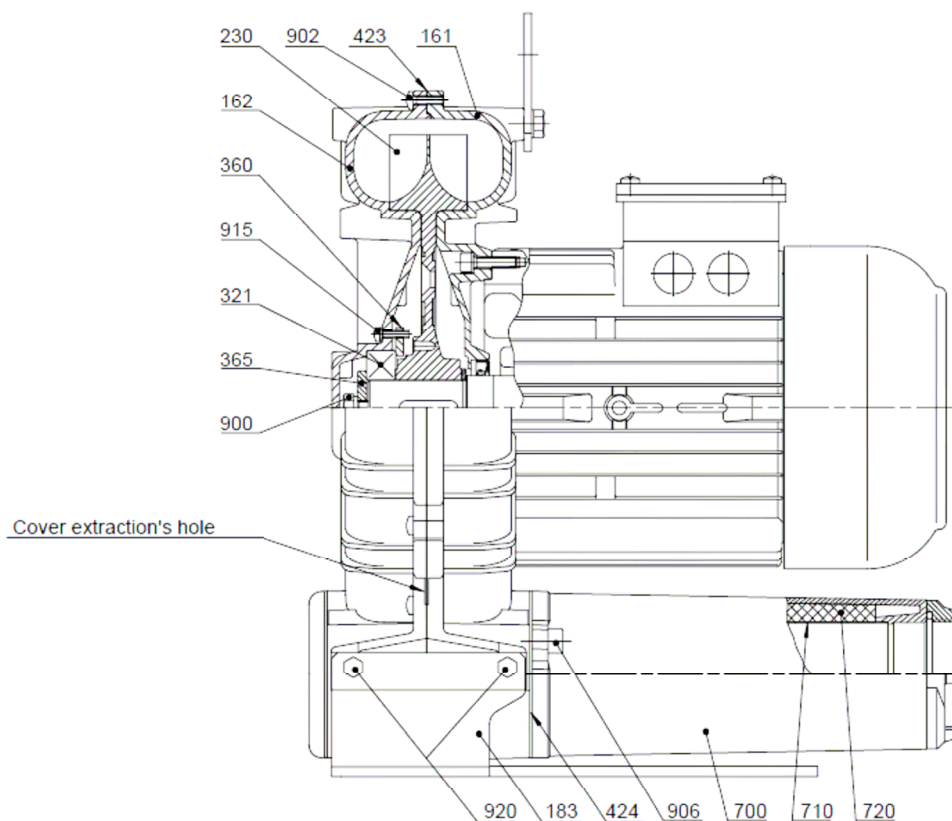

4. SILENCER HOUSING MOUNTING INSTRUCTIONS

The 'FJET' series was designed to provide maximum flexibility in the positioning of the silencer housings to meet various installation configurations.

The blower is supplied with the silencers configured as in Fig. 1

If this configuration needs to be modified, proceed as follows:

1. Identify the desired configuration (Fig.2, Fig.3, Fig.4).
2. **Disassembly of the silencer housing:**
 - 2.1 Remove the #906 screws.
 - 2.2 Take away the #700 silencer from the unit along with the #424 gasket.
3. **Disassembly of the #730 blind flange:**
 - 3.1 Remove the #909 screws, taking away the #730 flange along with the #427 gasket.

Reassemble in reverse order-do not forget the #427 gaskets.

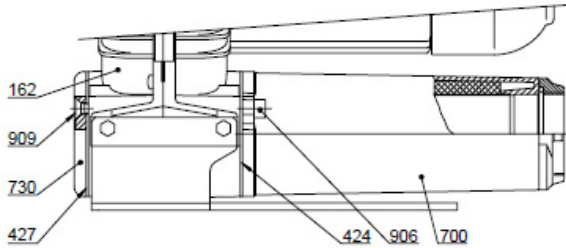

4.1 USING THE 90° MANIFOLD KIT TYPE CK (accessory)

The 90° manifold can only be installed on the #162 cover ports and as shown in the Figures below, there are multiple configurations.

The 90° manifold kit type CK comes supplied with; 1 x manifold 1 x #427 gasket and x M8x25 UNI 5739 screws.

To mount the 90° manifold, proceed as follows:

1. Disassemble the silencer housing (see point 2)
2. Place the #427 gasket between the #162 cover and the 90° manifold and seal with the M8x25 UNI 5739 screws.

Assemble the silencer housing in reverse order-do not forget the #424 gaskets.

Fig.2 with 90° manifold

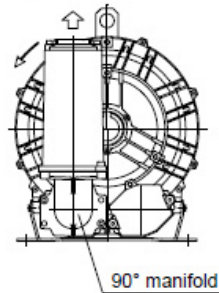

Fig.3 with two 90° manifolds

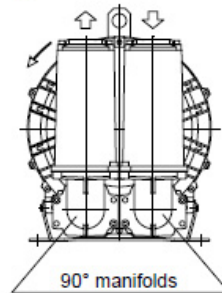

Fig.4 with 90° manifold

