

Automatic welding machine type LARON BL DIGITAL

OPERATING MANUAL

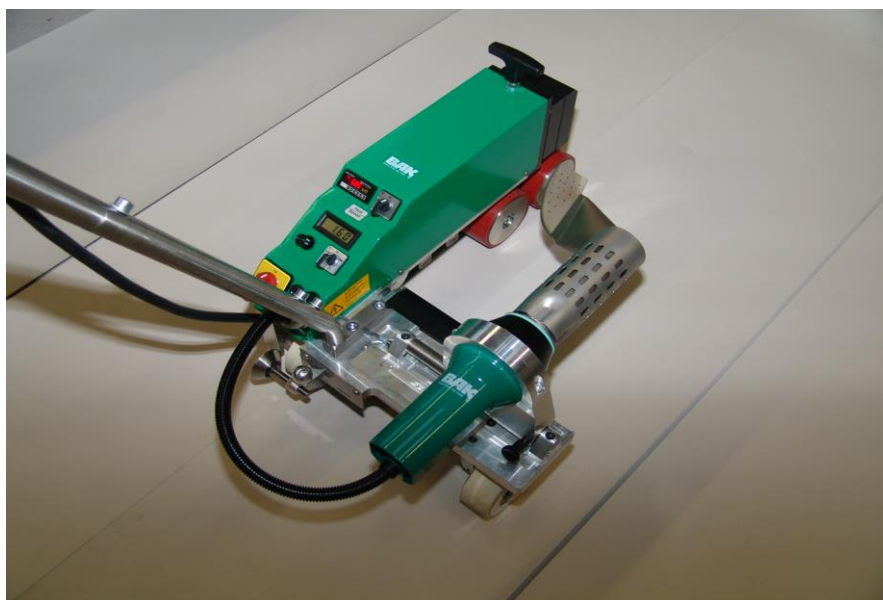

SAFETY



Danger to life

Unplug the tool before opening it as live components and connections are exposed.



Danger of fire and explosion in case of incorrect use of the automatic welding machine, especially near combustible materials and/or explosive gases.



Danger of burns

Allow the tool to cool down.



Connect the tool to a socket outlet with protective earth conductor. Any interruption of the protective earth conductor within or outside the tool is dangerous! Use only extension cables with a protective earth conductor.



The **voltage rating** stated on the tool should correspond to the mains voltage.



For personal protection, we strongly recommend to connect the tool to a **RCCB** (**R**esidual **C**urrent **C**ircuit **B**reaker) before using it on construction sites.



Do not leave the tool unobserved. The tool must not be used by children or people with limited physically, sensory or mental ability. Children must be supervised to prevent that they play with the tool.



Protect the device from damp and wet!

WARRANTY AND LIABILITY

Warranty and liability apply from the date of purchase (documented by the invoice/delivery note) according to the currently valid general terms of business from BAK. BAK refuses to honour any warranty for devices which are not in their original condition. BAK devices may never be reconfigured and/or modified.

BAK reserves the right to deny any responsibility if this is ignored. No liability can be assumed by BAK for incorrect installation and/or use as well as natural wear and tear of components (e.g. heating elements).

Note:

This operating manual must be available to the installation and operating personnel at all times. Read these operating instructions carefully before installing and using the device.

Copyright:

This document must not be disclosed to third parties without the explicit written approval of BAK. Any forms of reproduction or copying and electronic storage are prohibited.

INTENDED USE

The Laron is an automatic welding machine for overlap welding of roofing membranes made of PE, PVC, TPO, ECB, EPDM, CSPE and bitumen. The machine can also be used in areas close to edges and on uneven surfaces.

Any improper use may result in dangers for the operator or third parties or may adversely affect machines and assets.

Only use the automatic welding machine if in technically perfect condition and for the purposes for which they are intended while observing the operating instructions.

The tool can be used for the applications mentioned in the present operating instructions only!

Stop operating the automatic welding machine if:

- connecting line or plug have been damaged.
- safety installations have been damaged.
- changes occur in the operating state.

EXTENSION CORDS

When using extension cords the minimum diameter of cables must be observed. Extension cords must be approved and marked for their place of utilisation.

Before operating the machine examine the tool adjustment.

Proceed with adjustments only in cold condition (danger of burns).

NOZZLE ADJUSTMENT

Changes of the nozzle adjustments can be done if screws are loosened
For recommended settings use the following sketch:

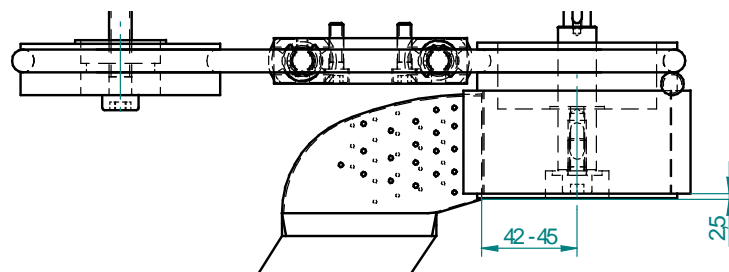

GUIDE ROLLER ADJUSTMENT

- Bring the automatic welding machine into the welding position.
- Push the transport roller to the right in welding position, take care that the spring sheet engages.
- Push the guide roller downward and fix it with the hexagon nut on the threaded bar.
- Outside edge of the overlap, outside edge of pressure roll and outside edge of guide roller must form a line. Please refer to the sketch below:

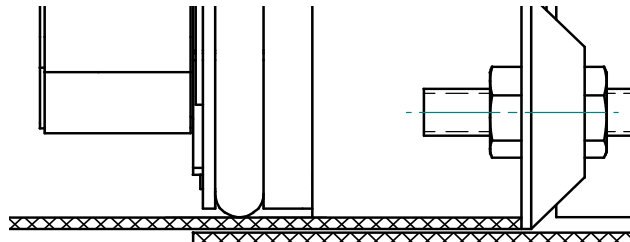

START UP OF THE WELDING MACHINE

Before connecting the tool to the mains supply please check that:

- Main switch is on pos. 0 OFF.
- Drive switch is on pos. 0.
- Heating switch is on pos. 0.
- Potentiometer of the air flow is on pos. 0 (100%).
- The hot air blower is on pos. stand by (lifted up).
- Put the plug into the socket.
- Put the main switch on pos. 01.
- The tool now heats up to the last selected set temperature.

CONTROLLER ADJUSTMENT

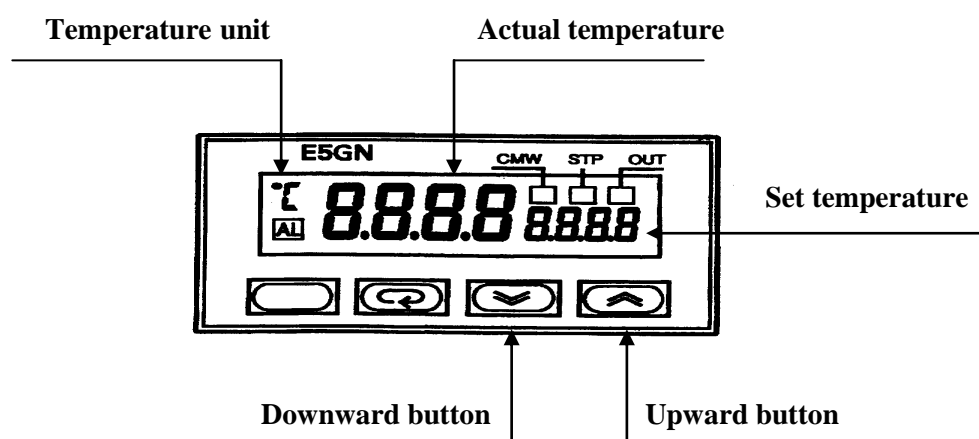

- Select on the potentiometer the desired welding speed.
- On switching position ON the drive starts immediately and is constantly running.
- On switching position AUTO the drive starts only after sliding the nozzle into the welding seam and stops immediately after taking out the nozzle.
- To separate the automatic welding machine from the electric system, change the main switch to “OFF” und unplug the mains plug.

ASSISTANCE AND SUPPORT

The BAK group and its authorised service centres offer free support and assistance in the area of applications technology.

Our specialists will be pleased to help you.

Customer service and orders:

BAK Thermoplastic Welding Technology AG

Industriestrasse 6

CH-6064 Kerns/Switzerland

Telefon: (0041) 041 661 22 50

Telefax: (0041) 041 661 22 51

E-Mail: info@bak-ag.com

ACCESSORIES

Get the best results by using BAK-accessories and spare parts.

Further information can be found in our brochures.

SERVICE AND REPAIR

Repairs should only be carried out by authorized BAK service centres. These guarantee a professional and reliable 24-hour repair service with original spare parts. A heating element can be changed by qualified personal.

If the mains connection of the device is damaged, it should be replaced by the manufacturer, from an authorized BAK service centre or a qualified person to avoid danger.

SHIPPING

For repairs, please return the device appropriately packed for transport to your next BAK service centre.

Shipping to CUSTOMER ACCOUNT.

Technical modifications reserved. In case of doubt, consultation with BAK is required. Images and drawings may deviate from the original. Changes reserved.

TRANSPORT – HANDLING – STORAGE

Transport:

The welding machine is packed appropriately and must be protected from moisture.

Handling:

The shipment must be checked if complete and for transport damage. In the event of transport damage, the defect must be confirmed in writing at the time of the delivery by the carrier. The seller must be promptly informed in writing!

Storage:

In the case of temporary storage, the welding machine should be kept packed and must be protected from moisture. In the case of damage resulting from improper storage, no warranty claim will be honoured.

DISPOSAL



Power tools, accessories and packaging should be sorted for environmental friendly recycling.

Do not dispose power tools together with household waste!

Only EU countries: According to the European Directive 2002/96/EC on waste electrical and electronic equipment and its incorporation into national law, power tools that are no longer operational must be separately collected and sent to be environmental friendly recycled.

TECHNICAL DATA

Technical Data		LarOn BL digital	
Voltage	VAC	230	230
Frequency	Hz	50 / 60	
Power consumption	W	4600 / 5700	
Temperature	°C	20 – 620, stepless adjustable	
Drive	m/min	0.5 – 7, stepless adjustable	
Welding pressure	N	35	
Weight	kg	620 x 400 x 320	
Size LxWxH	Mm (LxBxH)	230	
CE	CE		
Protection of class 1			

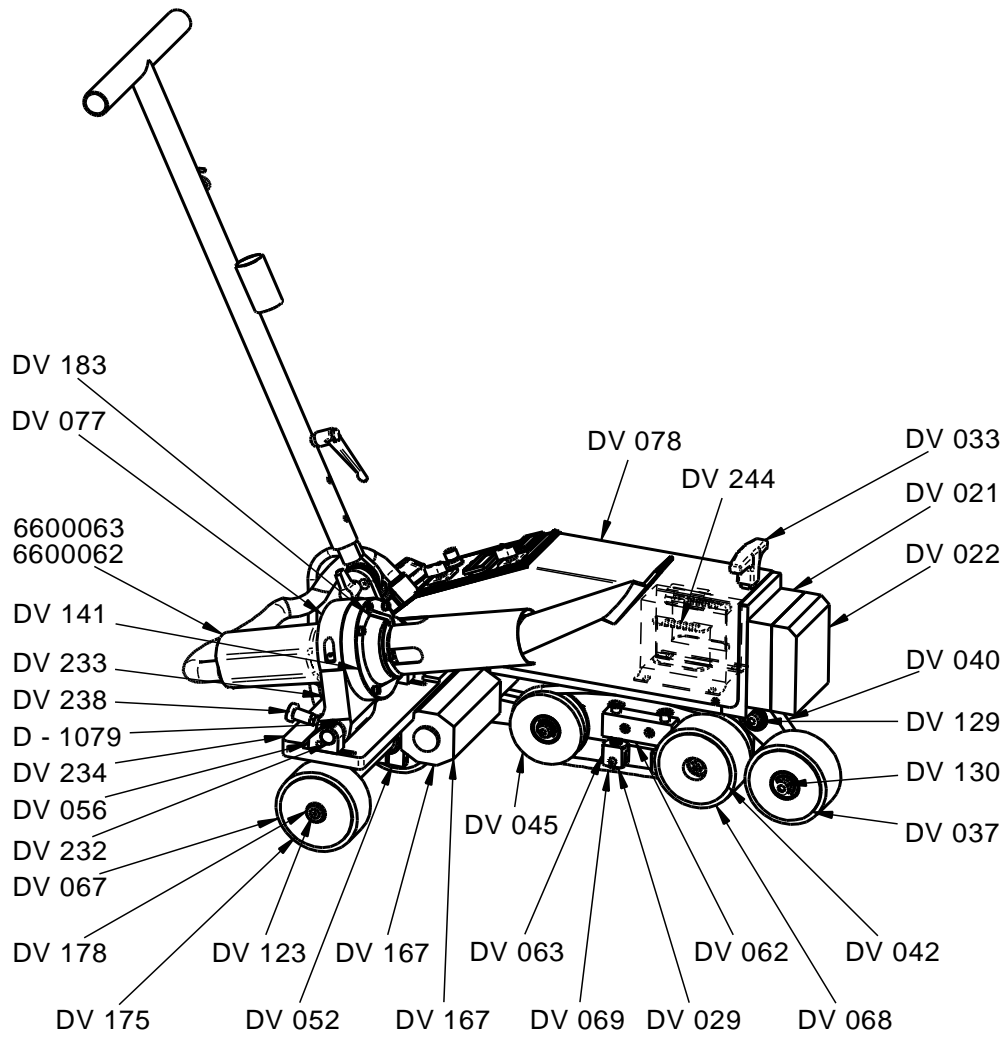

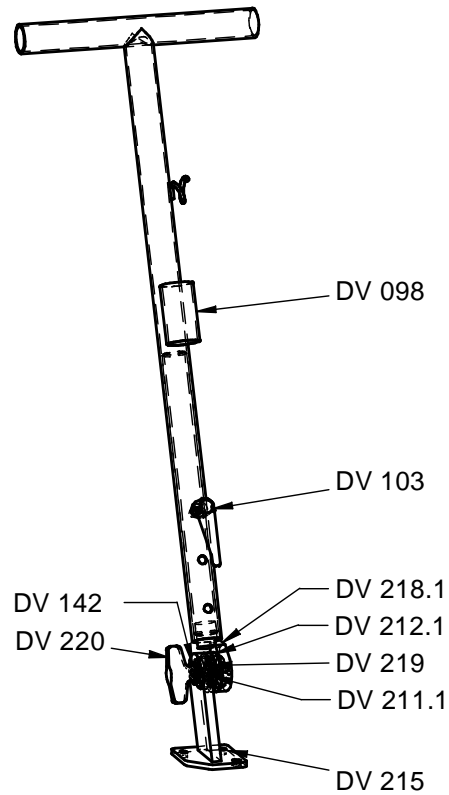
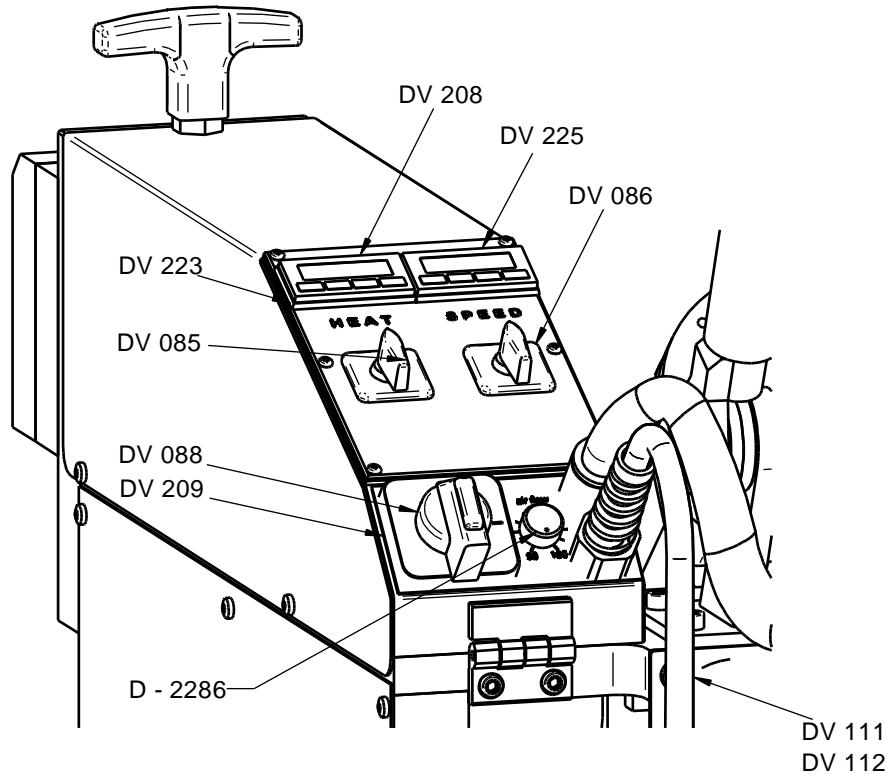

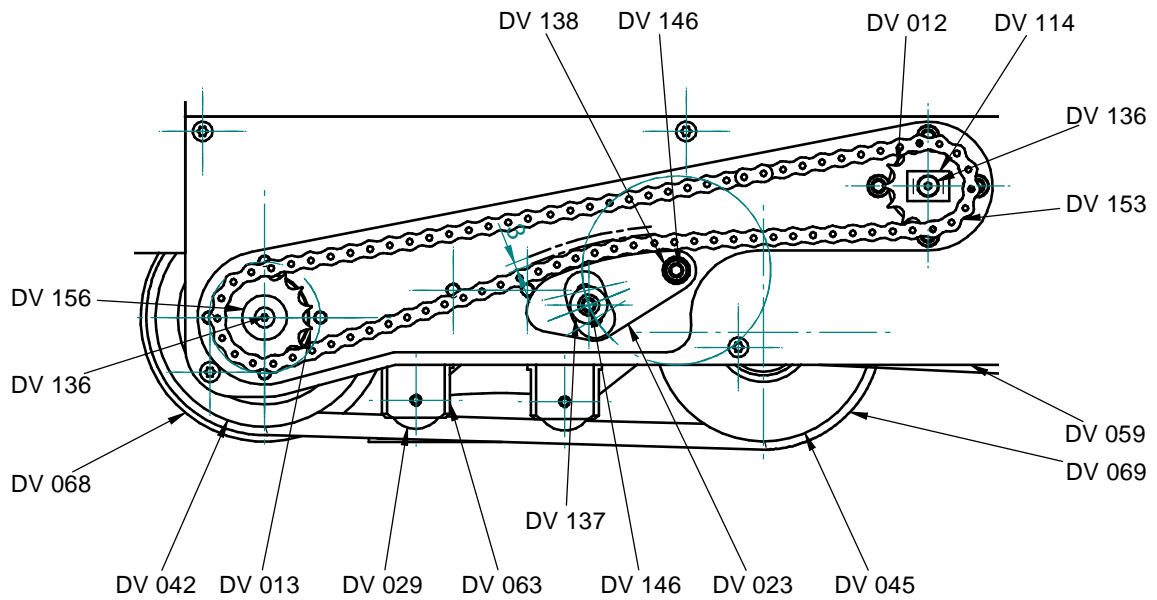
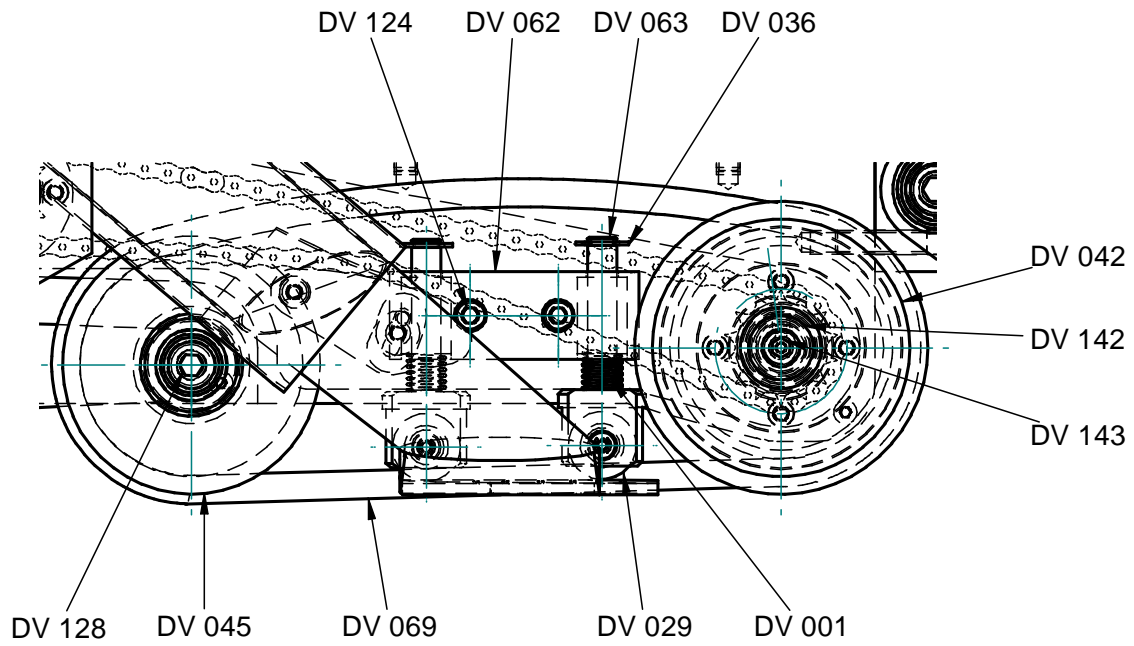

Art. no.	Description	Art. no.	Description
6600062	Eron 230V Laron complete	6601162	Cheese head screw, M6x20, DIN912(DV124)
6600063	Eron 400V Laron complete	6601164	Cheese head screw, M10x40, DIN7984(DV128)
6601246	O-ring 19x3.5 DIN3771 (D-1079)	6601165	Cheese head screw, M12x35, DIN7984 (DV129)
6601111	Pressure spring (DV001)	6601166	Cheese head screw, M12x70, DIN7984 (DV130)
6601112	Sprocket wheel, z=13 (DV012)	6601168	Countersunk screw, M4x10, DIN7991 (DV136)
6601113	Sprocket wheel, z=14 (DV013)	6601169	Disk A5,3 DIN9021 (DV137)
6601114	Roller chain (DV153)	6601170	Disk A5,3 DIN125 (DV138)
6601118	Weight 1 (DV021)	6601172	Cone ring Eron (DV141)
6601119	Weight 2 (DV022)	6601173	Disk B8,4 DIN9021 (DV142)
6601120	Chain tension adjuster (DV023)	6601174	Cheese head screw M8x16, DIN912 (DV143)
6601121	Guide roller (DV029)	6601175	Cheese head screw M5x16, DIN912 (DV146)
6601123	T-handle (DV033)	6601255	Disk B6,4 DIN9021 (DV156)
6601125	Circlip RA9 (DV036)	6601146	Housing Laron (DV158)
6601126	Drag roller (DV037)	6601235	Planetary gear motor (DV167)
6601127	Rocker drag roller (DV040)	6601237	Transport roller V2A (DV175)
6601128	Drive pressure roller (DV042)	6601238	Cover transport roller (DV178)
6601129	Round belt roller (DV045)	6601247	Ground piece (DV183)
6601133	Fixation block (DV052)	6601256	Controller Laron 2010 (DV208)
6601135	Bearing (DV056)	6601259	Front panel 2 (DV209)
6601138	Gear sheet (DV059)	6601260	Potentiometer 47K (D-2286)
6601139	Block guide pillar (DV062)	6601261	Locking disk (DV211.1)
6601140	Guide pillar (DV063)	6601262	Locking disk (DV212.1)
6601212	Rubber ring white (DV067)	6601263	Handlebar base plate (DV215)
6601142	Silicon ring (DV068)	6601264	Handlebar bottom (DV218.1)
6601143	Round belt (DV069)	6601265	Pressure spring (DV219)
6601145	Locking ring Eron, upper part (DV077)	6601266	Stainless steel wing nut (DV220)
6601217	Cam switch, 1-pole (DV085)	6601279	Front panel Laron digital (DV223)
6601218	Cam switch, hand-off-auto (DV086)	6601280	Trimmer Laron digital (DV224)
6601220	Main switch (DV088)	6601281	Controller speed Laron (DV225)
6601152	Grip of steering bar (DV098)	6601274	Shaft 2 (DV232)
6601155	Adjustable clamping lever (DV103)	6601275	Locking ring Eron, lower part 2 (DV233)
6601159	Power supply cord 230V 3x2.5 (DV111)	6601276	Base plate 2 (DV234)
6601160	Power supply cord 400V 3x2.5 (DV112)	6601273	Locking pin (DV238)
6601161	Sprocket wheel clamp (DV114)	6601277	Mainboard Laron (DV239)
6601254	Countersunk screw, M6x16 DIN7991 (DV123)	6601278	Transformer (DV244)

ERON LARON 230V/400V

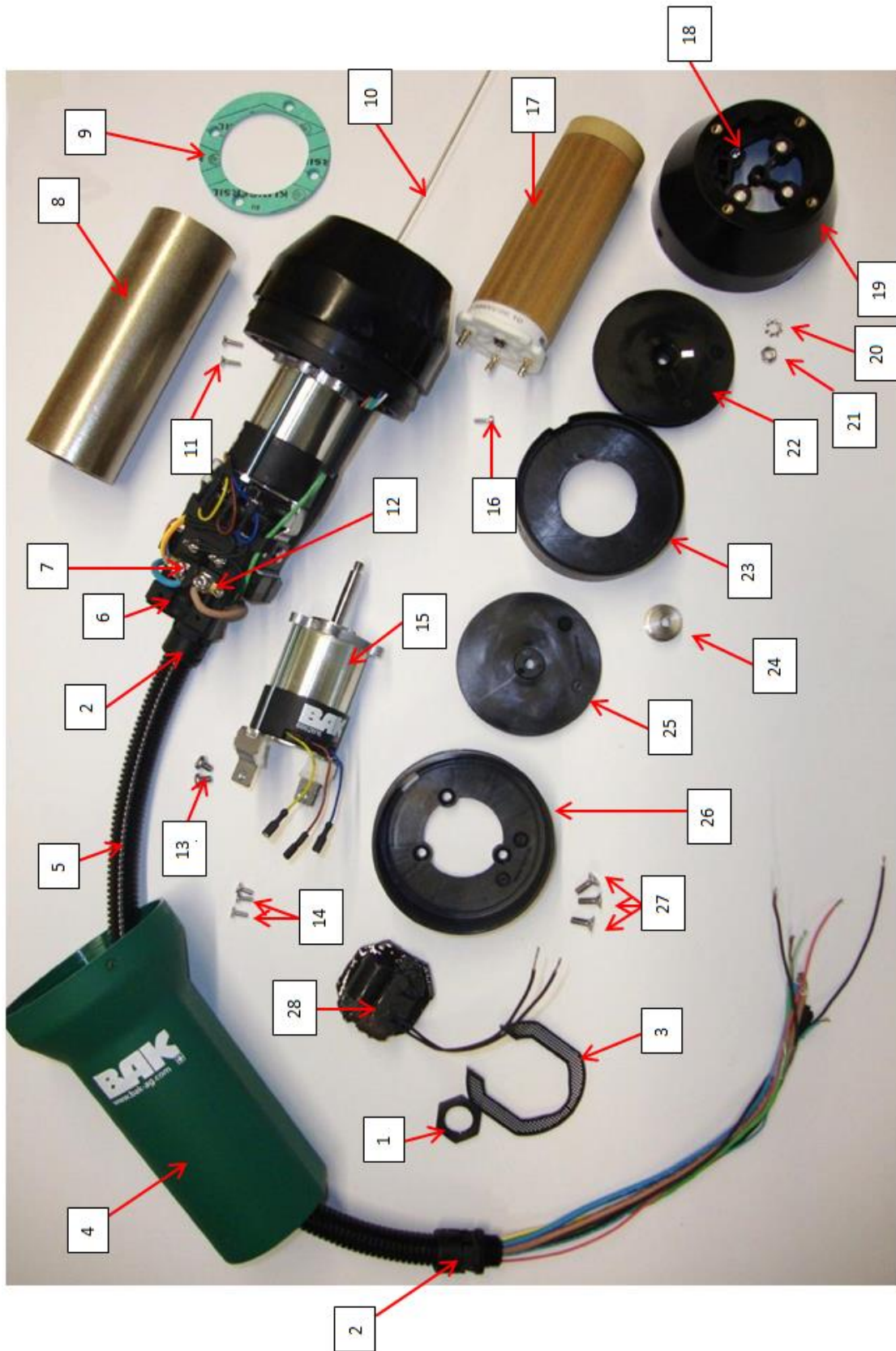

Spare parts list Eron Laron BL 230V/400V

1	6603151	2 Nut M16
2	6600648	2 Hose coupling straight
3	6600601	1 Air filter
4	6600639	1 Handle special
5	6600652	1 Cable protection corrugated tube
6	6600644	1 Terminal support
7	6101243	2 Thread forming fillister head screw M4 x 8
8	5101274	1 Mica tube ø 47.6 x 134mm
9	5101270	1 Gasket 70x48x4
10	6112693	1 Thermocouple
11	6600616	2 Countersunk screw, 3(30)x10mm
12	6100435	2 Torsional protection washer
13	6100436	2 Pan head screw M4x6
14	6600603	3 Countersunk screw, 3(30)x8mm
15	6602617	1 BL-Motor complet with flange and connection piece Eron 230V
16	6600621	1 PT screw KL30x8
17	5107612	1 Heating element type 44/39A1, 230V/2200+2200W
17	5107613	1 Heating element type 44/39A1, 400V/2750+2750W
18	6600615	1 Photo transistor
19	6600638	1 Connecting head complete (with 4x660618, 3x6600619, 3x6600620, 3x6601065)
20	6600848	1 Lock washer
21	6100287	1 Hexagon nut M5
22	6600637	1 Turbine
23	6600614	1 Stripper
24	6101251	1 Steel hub
25	6600636	1 Turbine
26	6600613	1 Turbine housing lower part
27	6100284	3 Countersunk screw M4x12, Torx
28	6602610	1 Circuit board HLG V3.01, Eron Laron
	5108222	1 Overlap welding nozzle 40mm, perforated

